

# C 802

Control valves

ON/OFF option electrically controlled,  
solenoid valve normally open

## Technical Data Sheet



## Description

The control valves C 802 controlled thanks to a solenoid valve. It is hydraulically used to regulate a flow rate in a tank, a network of water distribution, in pump suction or any other use where ON/OFF duty is required. PFA depending on solenoid valve.



### C 802

ON/OFF option electrically controlled, solenoid valve normally open

DN "	mm	PN	PFA in bar	PS				Cat	Ref.	Weight* Kg
				L1	L2	G1	G2			
1 1/2		10/16/25	25	25	25	x	x	4.3	<b>149B010644</b>	8
	40	10/16/25	25	25	25	x	x	4.3	<b>149B010645</b>	12
	50	10/16/25	25	25	25	x	x	4.3	<b>149B010646</b>	13
	65	10/16/25	25	25	25	x	x	4.3	<b>149B80206N</b>	21
	80	10/16/25	25	20	25	x	x	4.3	<b>149B80208N</b>	26
	100	10/16	16	16	16	x	x	4.3	<b>149B80210N</b>	39
	125	10/16	16	16	16	x	x	4.3	<b>149B80211N</b>	59
	150	10/16	16	16	16	x	x	4.3	<b>149B80212N</b>	73
	200	10	10	10	10	x	x	4.3	<b>149B80214N</b>	122
	250	10	10	10	10	x	x	I	<b>149B80215N</b>	208
	300	10	10	10	10	x	x	I	<b>149B80216N</b>	328

\* Weight of valve alone

#### Important notice :

The indicated pressure for the different categories of fluids (L1/L2/G1/G2) is under no condition a guarantee of use. Therefore, it is essential to validate the use of products under given operating conditions.

Technical features	
Operating temperature	-10°C to 80°C, for temperatures over 80°C, consult us
Upstream pressure	Mini. : 1 bar / Maxi. : 25 bar (see table above)
Connection	DN 40 to 300 mm : with flange PN (see table above) DN 1"1/2 : threaded F/F
Mediums	Clear water 2 mm
Vertical mounting	In optional

## Nomenclature and materials

N°	Description	Materials
1	Membrane	EPDM/Polyamide
2	Position indicator with purge	Brass and stainless steel
3	Valve head high pressure	Ductile iron / Epoxy Int/Ext
4	Nuts and bolts	Stainless steel
5	Removable streamlined	Stainless steel
6	Body drain plug	Brass
7	Reversible seal	EPDM
8	Body high pressure	Ductile iron / Epoxy Int/Ext 150µ ± 50µ
9-10	Valve	Chromed brass
11	Stem	Stainless steel
12	Flange	Stainless steel
13	Seal carrier	Bronze (DN40-50) Cast iron / Epoxy
14	Plate	Bronze (DN40-50) Cast iron / Epoxy
15	Spring	Stainless steel

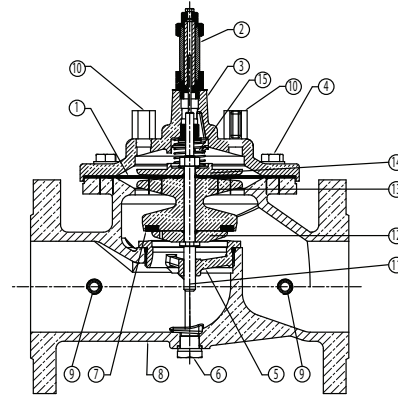

standard flow valve

## Approvals



### International construction Standards :

Directive 2014/68/UE

Connection with flange PN according to EN 1092-2

## Application

The control valves C 802 is used to regulate a flow rate in a tank, a network of water distribution, in pump suction or any other use where ON/OFF duty is required.

## Operation

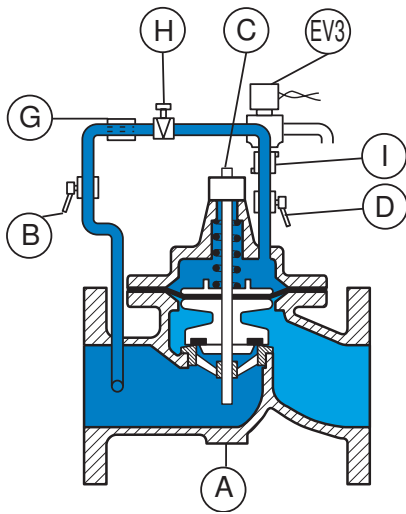

Solenoid valve 3-ways (EV3) is not under contact. The upper chamber empties to the atmosphere.  
The valve (A) is open.  
The flow control (I) controls the opening.

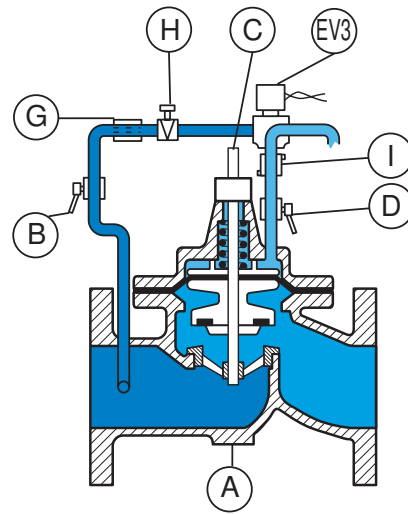

Solenoid valve 3-ways (EV3) is under contact. Upstream pressure fills the upper chamber, the valve closes.  
The needle valve (H) controls the closing.

## Installation

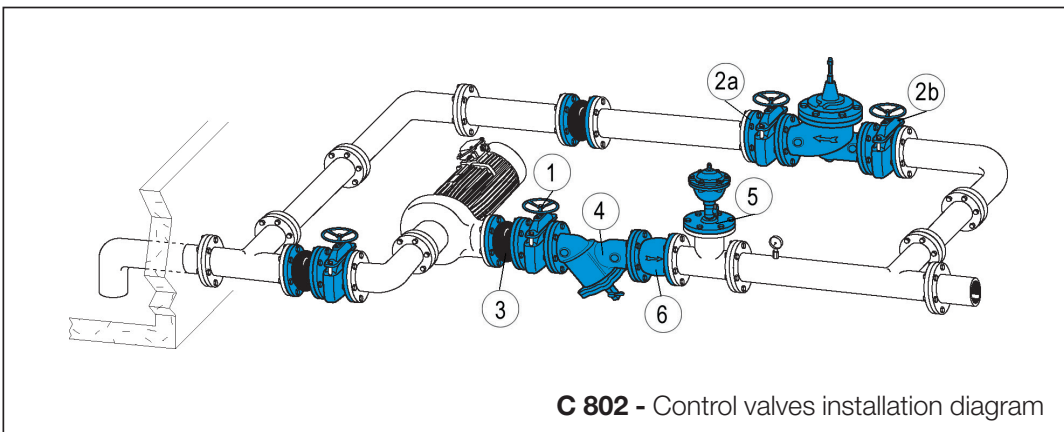

N°	Description
A	Main valve
B	Upstream isolation valve
C	Position indicator with drain
D	Chamber isolation valve
EV3	3 ways solenoid valve
G	Filter
H	Orifice-needle valve
I	Flow control
1	Isolation valve of the pump
2a	Upstream isolation valve of the by-pass
2b	Downstream isolation valve of the by-pass
3	Rubber expansion joint
4	Filter
5	Single function air valve
6	Non return valve of the pump

**Installation :**

- install a strainer upstream
- install an air relief valve downstream or at the high point near the control valve.
- horizontal setting up : the cap of the valve should be oriented to the top and inclined at 45° maximum.
- vertical setting up : change the spring of the main valve (option 7)

**Other types :**

- C801

## Maintenance

---

We recommend a maintenance programme of between 6 to 12 months according to the quality of the water and to the pressure :

- Purging the upper chamber
- Flushing the valves not frequently used
- Checking and cleaning filters of the pilot circuit and main piping system.
- Checking the working (pressures)

Every 5 years, general maintenance is advisable :

- Dismantling
- Cleaning of main valve and pilot valve
- Preventive removing of the seals (set available - please consult us)
- Reassembling and tests.

# Operating characteristics

## Choice of base valve

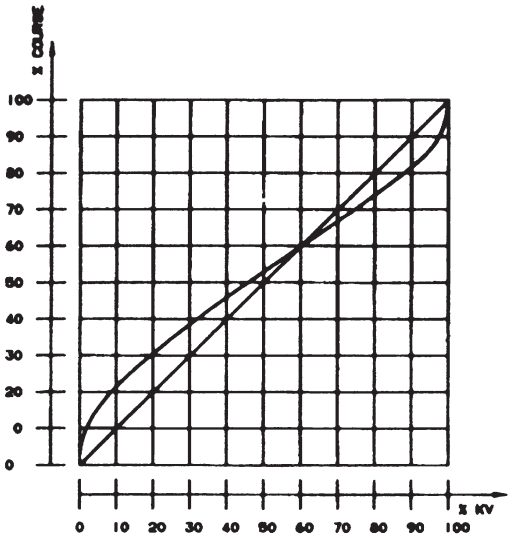

DN mm	Mini m³/h	Maxi m³/h	KV		ζ	PN bar	PFA bar	PN bar	PFA bar	PN bar	PFA bar
			m³/h	L/s							
1" 1/2	0,520	20,34	26,35	7,32	5,78	10/16	16	25	25	-	-
40	0,675	32,00	45,66	12,68	1,93	10/16	16	25	25	-	-
50	0,675	32,00	45,66	12,68	4,70	10/16	16	25	25	-	-
65	0,855	54,00	57,75	16,08	8,39	10/16	16	25	25	-	-
80	1,600	82,00	80,00	22,22	10,00	10/16	16	25	25	-	-
100	2,720	127,00	136,00	37,78	8,47	10/16	16	25	25	-	-
125	4,400	199,00	220,00	61,11	7,90	10/16	16	25	25	-	-
150	5,280	286,00	264,00	73,33	11,38	10/16	16	25	25	-	-
200	13,500	509,00	600,00	66,67	6,96	10	10	25	25	16	16
250	25,000	795,00	900,00	50,00	7,56	10	10	25	25	16	16
300	40,900	1145,00	1224,00	40,00	8,47	10	10	25	25	16	16

## Headloss chart

Solid line : Base valve completely open

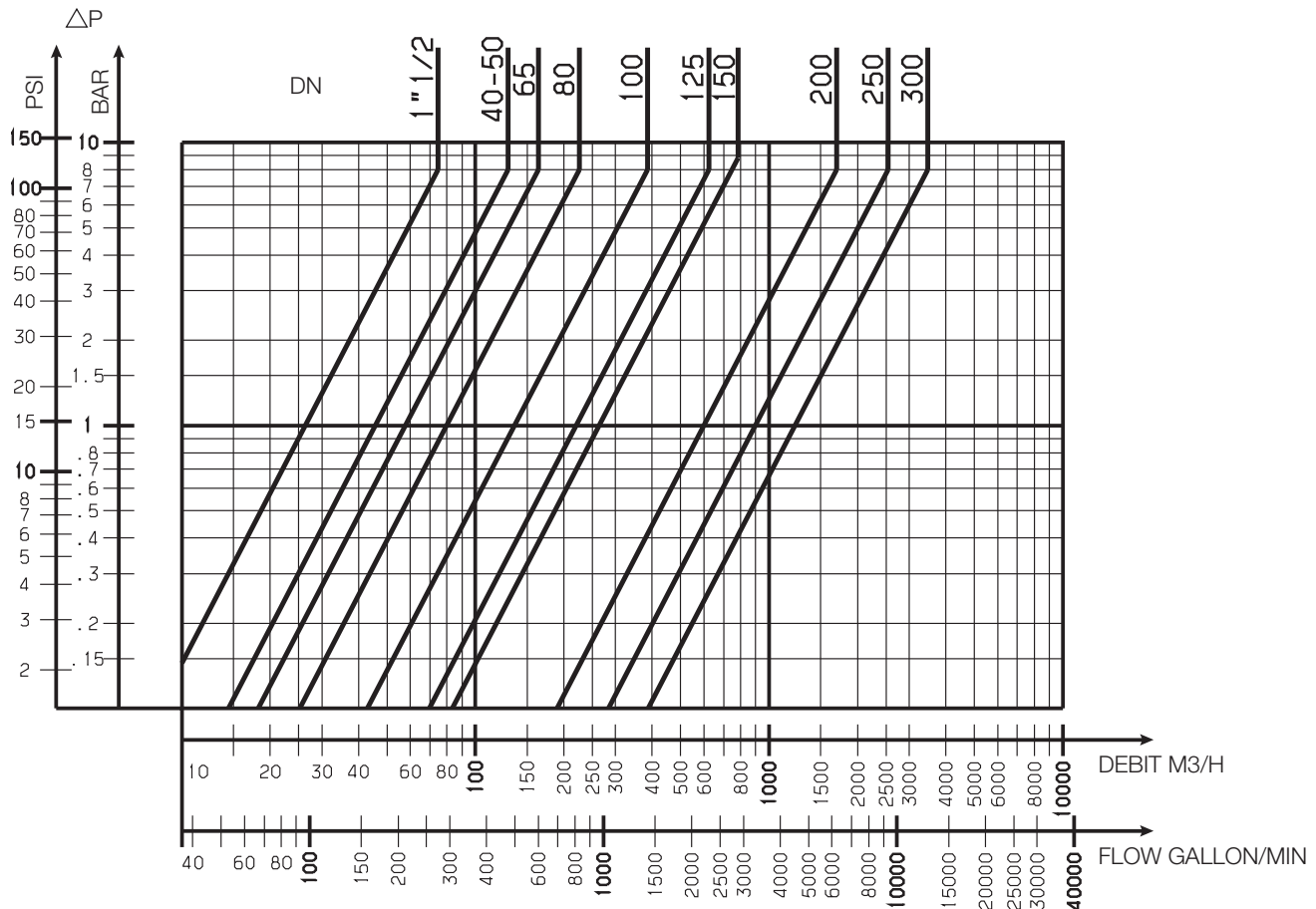

## Sizing

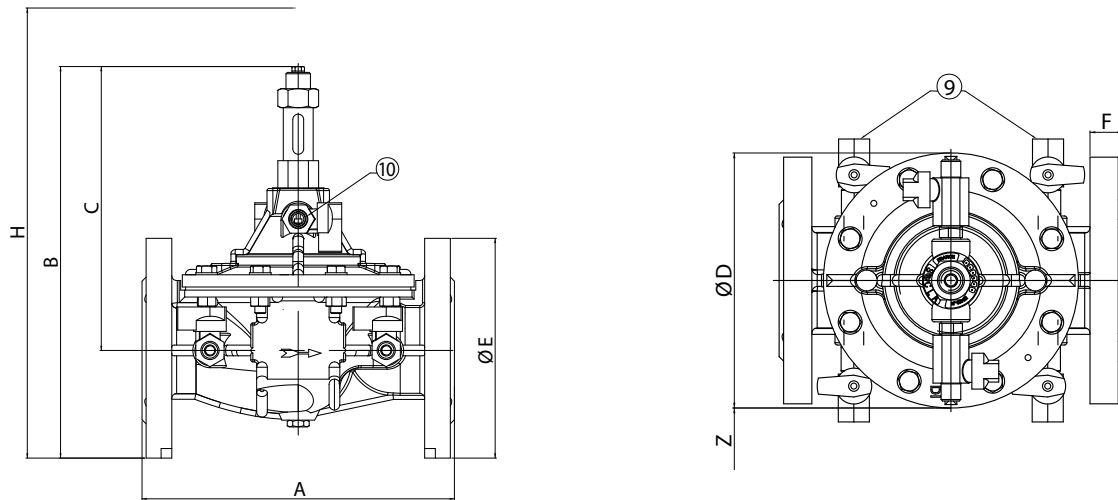

### standard flow valve

DN	A	B	C	Ø D	Ø E	F	H	Z	9	10
”	mm	mm	mm	mm	mm	mm	mm	mm	”	”
1 1/2(F/F)	230	267	210	170	6 pans <sup>(1)</sup>	-	400	254	1/4	3/8
40	230	285	210	170	152	23	400	254	1/4	3/8
50	230	285	210	170	161	23	400	254	1/4	3/8
65	290	352	257	200	185	24	470	254	3/8	1/4
80	310	372	272	217	200	26	500	254	3/8	3/8
100	350	423	302	241	235	28	510	254	3/8	3/8
125	400	506	371	296	270	30	570	254	3/8	3/8
150	480	551	401	363	300	20	650	254	3/8	3/8
200	600	709	529	467	360	22	750	254	3/8	3/8
250	730	844	631	587	425	24	900	254	1/2	1/2
300	850	975	730	680	486	27	1100	254	1/2	1/2

(1) 78/plats

## Other operating characteristics

### Cavitation

A too large differential pressure and a low downstream pressure may result in damage to the valve by cavitation.

To avoid it, refer to the cavitation curve and if needed, reduce the differential pressure by installing and connecting two or more control valves in same line (consult us).

Stainless steel seat and counter seat are standard.

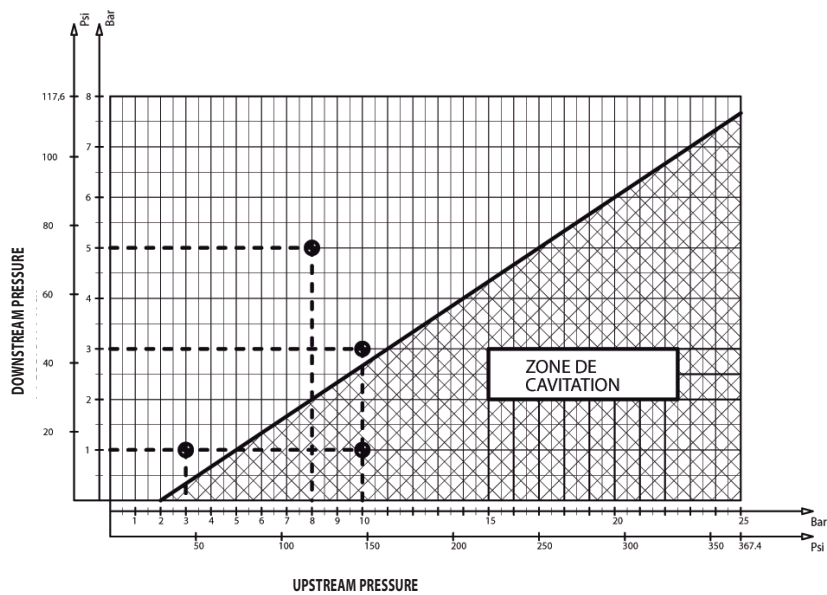

The descriptions and photographs contained in this product specification sheet are supplied by way of information only and are not binding.

Socla reserves the right to carry out any technical and design improvements to its products without prior notice. Warranty : All sales and contracts for sale are expressly conditioned on the buyer's assent to Socla terms and conditions found on its website at [www.socla.com](http://www.socla.com). Socla hereby objects to any term, different from or additional to Socla terms, contained in any buyer communication in any form, unless agreed to in a writing signed by an officer of Socla.



A WATTS Brand

Socla sas

365 rue du Lieutenant Putier • 71530 Virey-Le-Grand • France

Tel. +33 03 85 97 42 00 • Fax +33 03 85 97 42 42

[contact@wattswater.com](mailto:contact@wattswater.com) • [www.socla.com](http://www.socla.com)

ISO 9001 version 2015 / ISO 18001