

50F

Non-return ball valve

B System

Technical Data Sheet



Description

The non-return ball valve 50F consists of a self-cleaning ball lifted by the fluid and guided to a lateral seat, completely out of the way. This system provides a full-flow, even with loaded fluids, without any risk of blockage.

- Vertical and horizontal operation (position of the ball below the axis of the pipe)
- Minimum head loss
- Silent, robust
- Non incrustating materials
- Closing system : floating ball epoxy coated
- Sealing ensured by elastomer seal fixed on the seat



50F

Non-return ball valve - B System

DN		PFA in bar	Ref.	Weight Kg
"	mm			
1	25	10	149B2122	1,50
1 1/4	32	10	149B2123	2,00
1 1/2	40	10	149B2124	2,80
2	50	10	149B2125	3,60
2 1/2	65	10	149B2127	5,60
3	80	10	149B14077	12,80

Important notice :

The indicated pressure for the different categories of fluids (L1/L2/G1/G2) is under no condition a guarantee of use. Therefore, it is essential to validate the use of products under given operating conditions. The operating instructions are available on our website www.socla.com or by requesting from our sales department.

Technical features

Operating temperature	-10 °C to 80 °C
Permissible operating pressure (PFA) in water	See table above
Connection	Female / female, BSP
Mediums	Wasted water

Nomenclature and materials

N°	Description	Materials
1	Body	Cast iron / Epoxy
2	Ball	Thermodur
3	Seal	DN 1"1/2 CR
		Others DN NR
4	Flange	Cast iron / Epoxy
5	Nut	Stainless steel
6	Screw	Stainless steel

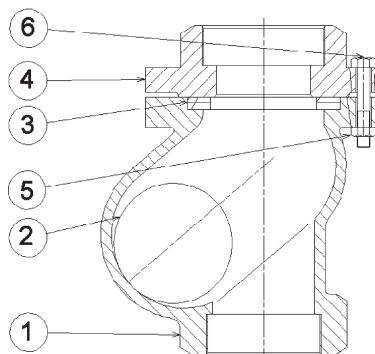

Approvals



International construction Standards :

Directive 2014/68/UE

Directive 89/106/CEE Standard EN12050-4

Thread connection according to NF E 03-005 ISO228

Application

Used as a suction cup or to prevent wasted water backflow.

This "all-purpose" range is also suitable for use in lifting of aggressive liquids and construction sites sanitation.

Operation

Direction for use :

- Solid line: Valve completely open
- Dotted line: opening stage of valve

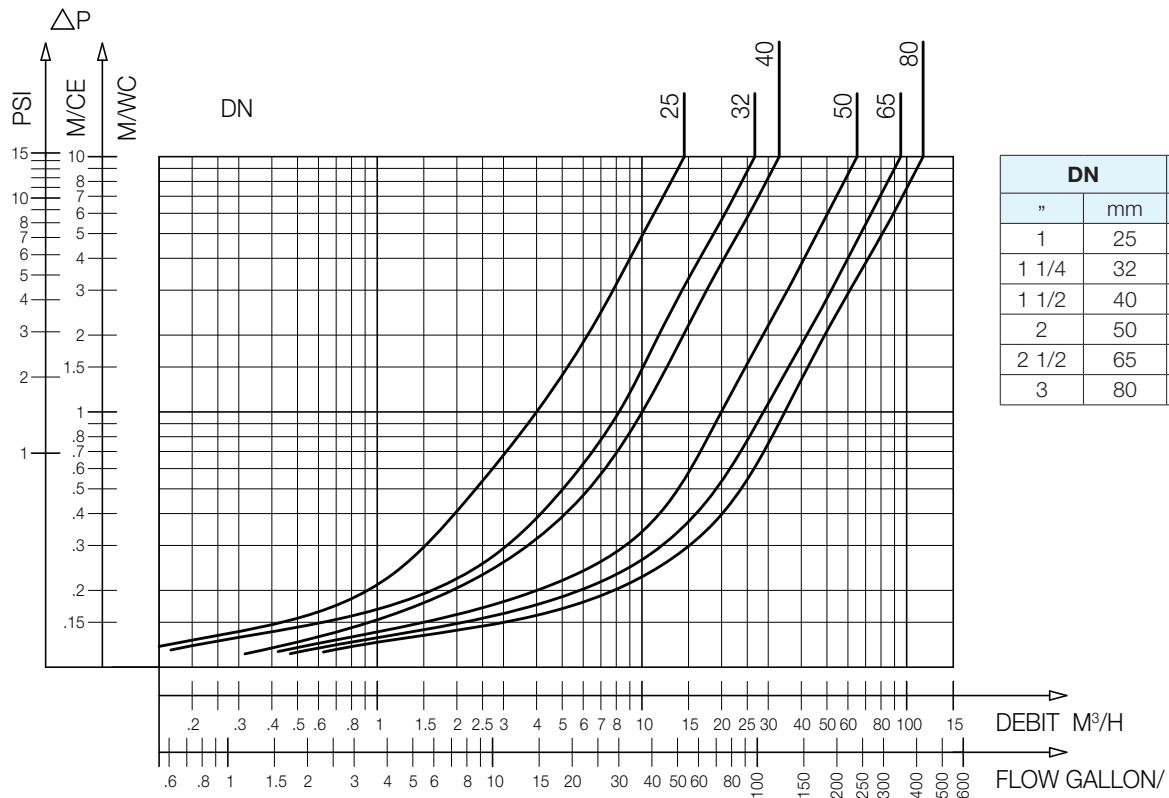

50F - Headloss chart

Sizing

A		B	C
"	mm	mm	mm
1	26/34	121	104
1 1/4	33/42	134	119
1 1/2	40/49	145	137
2	50/60	174	157
2 1/2	66/76	195	179
3	80/90	246	214

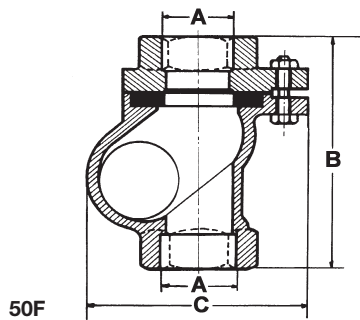

The descriptions and photographs contained in this product specification sheet are supplied by way of information only and are not binding.
 Socla reserves the right to carry out any technical and design improvements to its products without prior notice. Warranty : All sales and contracts for sale are expressly conditioned on the buyer's assent to Socla terms and conditions found on its website at www.socla.com. Socla hereby objects to any term, different from or additional to Socla terms, contained in any buyer communication in any form, unless agreed to in a writing signed by an officer of Socla.



A WATTS Brand

Socla sas

365 rue du Lieutenant Putier • 71530 Virey-Le-Grand • France

Tel. +33 03 85 97 42 00 • Fax +33 03 85 97 42 42

contact@wattswater.com • www.socla.com

ISO 9001 version 2015 / ISO 18001