

418/408

Non-return valves with ball, flanged
System B

Technical Data Sheet



Description

The non-return valves with ball, flanged 418/408 consists of a self-cleaning ball lifted by the fluid and guided to a lateral seat, completely out of the way. This system provides a full bore, even with loaded fluids, without any risk of blockage.

- Vertical ascending and horizontal position (position the ball housing above the axis of the pipe)
- Minimum head loss
- Silent, robust
- Non incrustating materials
- Sealing guaranteed by the coating of the ball



418/408

Non-return valves with ball, flanged - System B

DN	PN	PFA in bar	PS in bar				Cat	Ref.	Weight Kg
			L1	L2	G1	G2			
2	50	10/16	10	10	10	10	I	149B3140	5,5
2 1/2	65	10/16	10	10	10	10	I	149B3141	9,1
3	80	10/16	10	10	10	10	I	149B3142	13,3
4	100	10/16	10	10	10	10	I	149B3143	20,9
5	125	10/16	10	10	0,5	10	I	149B3144	27,5
6	150	10/16	10	10	0,5	10	I	149B3145	35,7
8	200	10	10	10	0,5	10	I	149B3146	63,7
10	250*	10	10	10	0,5	10	I	149B2907	128,9
12	300*	10	10	10	0,5	10	I	149B2908	220,1
14	350*	10	10	10	0,5	10	I	149B2909	345,6

*Type 408

Options: Specific coating and flanges drilling, thickness 250µm, from DN 80 to DN350 different ball weights are sometime necessary to prevent vibration and water hammer , stainless steel screws A4, materials ... consult us

Important notice :

The indicated pressure for the different categories of fluids (L1/L2/G1/G2) is under no condition a guarantee of use. Therefore, it is essential to validate the use of products under given operating conditions.

Technical features

Operating temperature	-10 °C to 80 °C
Permissible operating pressure (PFA) in water	See table above
Maximum permissible pressure (PS) other mediums	See table above
Connection	Flanges drilled PN (see table)
Mediums	Waste water, viscous liquids, loaded liquids

Nomenclature and materials

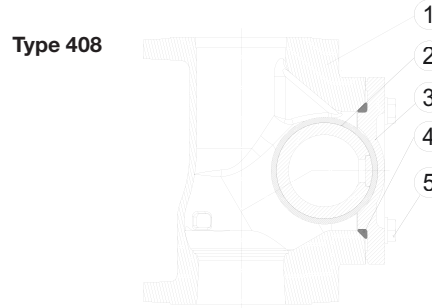
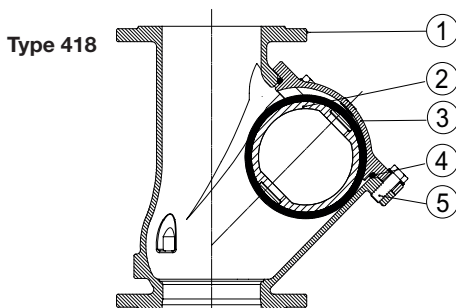

N°	Description	Materials	EURO	ANSI
1	Body	Ductile iron / Epoxy	EN 1563, EN-GJS-400-15	ASTM A 536 60-40-18
2	Ball	Aluminium / NBR DN 50 to 100 Cast iron / NBR DN 125 to 350		
3	Cover	Ductile iron / Epoxy	EN 1563, EN-GJS-400-15	ASTM A 536 60-40-18
4	Seal	NBR		
5	Screw-washer	Stainless steel A2	EN 10088-3 X5Cr-Ni18-10	NF EN 150 3506

Option : the component list may be substituted with equivalent or higher class materials without prior notification.

Approvals



International construction Standards :

Directive 2014/68/UE
CE Conformity Regulation 305/2011/UE Standard EN12050-4
Flange drilling according to EN558

Length according to EN558 series 48 (except DN 350 : type 408)
Ductile iron body EN-GJS 400-15
Tightness : Category A according to ISO 5208

Tests :

Hydraulic test according to EN 12050-4

Application

The non-return valves with ball, flanged 418/408 designed in accordance with EN 12050-4, provide optimum protection for pump at the discharge station against the backflow of waste water and charged or viscous fluids, sanitation.

Installation

Installation :

Before putting valve into operation, check that:

- the working conditions are compatible with the details given on the identification plate, the instruction notice and the manufacturer's detail,
- the valve works effectively when tried (carry out a few opening and closing operations of the closing system),
- the valve is free-pollution inside.

On a new installation or after maintenance, the circuit must be rinsed with the valve completely open in order to remove solid matter which may damage the internal parts of the valve.

Commissioning :

The installation should be put under pressure progressively to avoid damage which might occur to internal components.

Make sure that when flow stops the valve maintains pressure well and that there is no water-hammer which might damage the valve or installation. If there is water-hammer, an anti-water hammer system must be added to the installation.

During a prolonged stoppage, a change in the state of the fluid may result in damage when the installation is brought back into service (solidification...). Establish an adequate procedure program for cleaning the system.

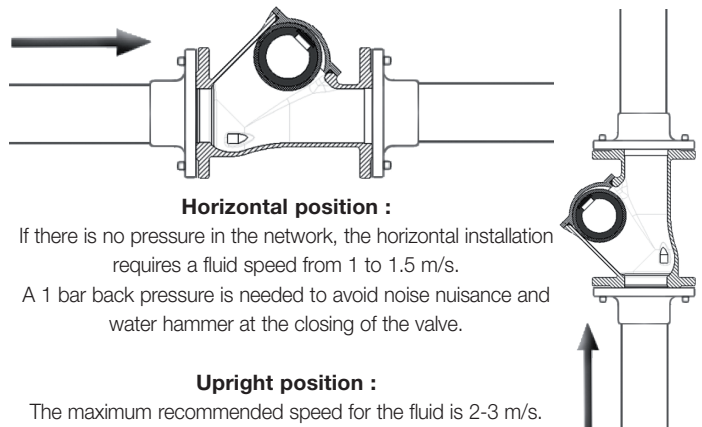

Maintenance

• Removing :

1. Unscrew the support screw assembly (N°5)
2. Remove the cover (N°2)
3. Remove the O-ring (N°4)
4. Tip over the body (N°1) for remove the ball (N°3)

• Reassembly :

Before reassembling the valve, check the condition of the seal. If necessary, clean and grease it by using appropriate grease.

1. Place the ball (N°3) in the body (N°1)
2. Put in place the O-ring (N°4) on the cover (N°2)
3. Put in place the cover (N°2) on the body (N°1)
4. Tighten the screw assembly (N°5) to the contact and then :
 - a. Tighten to the couple of 35 Nm for the FIG.418 up to DN100 included
 - b. Tighten with a suitable tool for the others references

Type 418

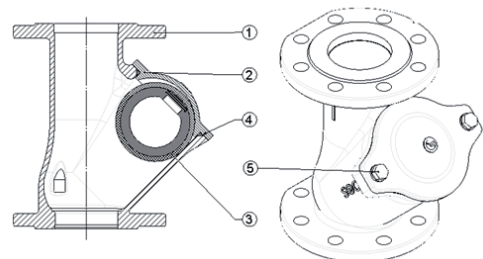

Type 408

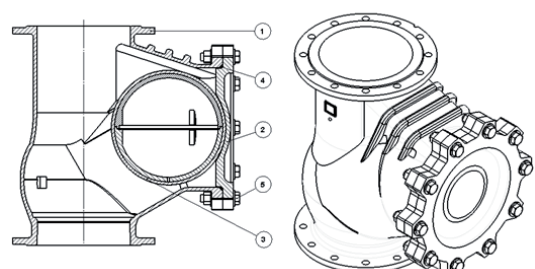

Operation

Direction for use :

- Solid line: Valve completely open

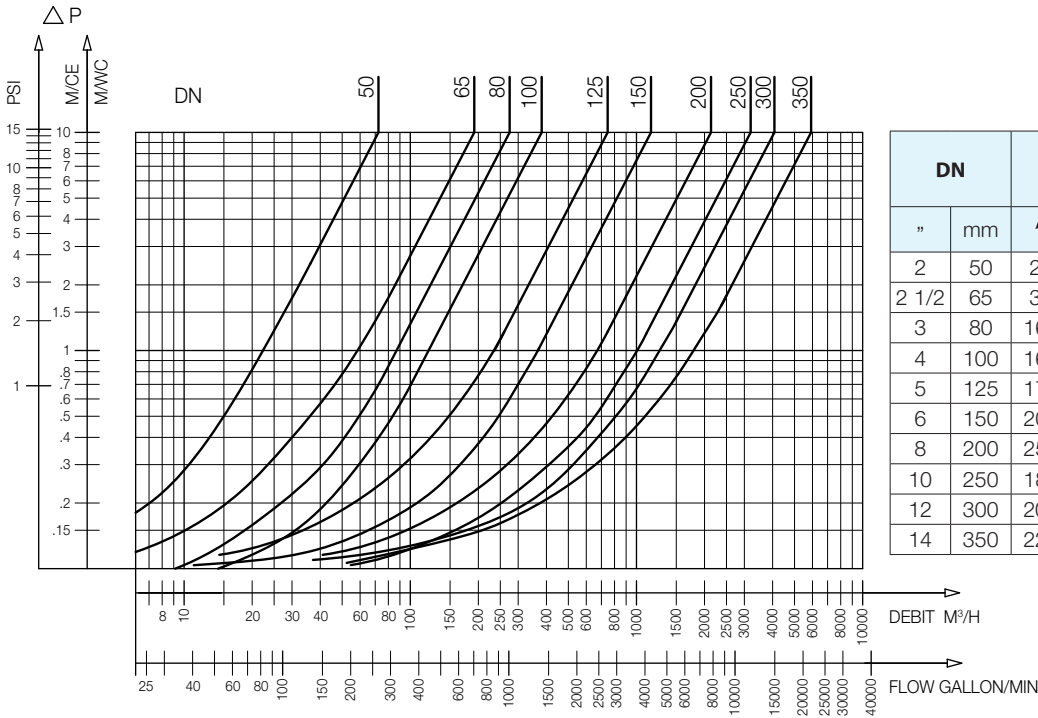

DN		Opening pressure in mm/CE		Kv	ζ
"	mm	↑	↔	m³/H	
2	50	25	Near to 0	72,3	1,90
2 1/2	65	30		192,3	0,77
3	80	160		275,8	0,86
4	100	160		381,0	1,10
5	125	170		746,4	0,70
6	150	200		1161,0	0,60
8	200	250		2136,3	0,56
10	250	180		3198,2	0,61
12	300	200		4153,4	0,75
14	350	220		5861,6	0,70

418/408 - Headloss chart

Sizing

DN A		B	C	D
"	mm	mm	mm	mm
2	50	200	165	173
2 1/2	65	240	185	214
3	80	260	200	252
4	100	300	220	289
5	125	350	250	368
6	150	400	285	424
8	200	500	340	509
10**	250	600	400	582
12**	300	700	455	721
14**	350	875	505	820

**Type 408

Width between flanges according to EN 558-1 series 48 except DN 350

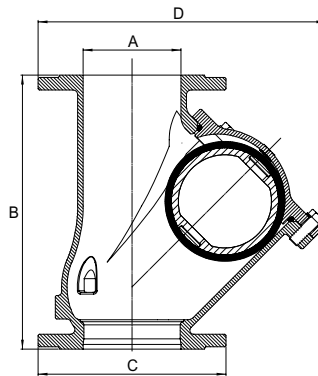

Type 418

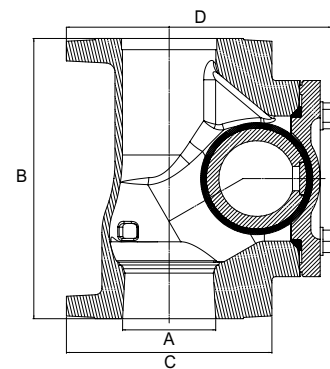

Type 408

The descriptions and photographs contained in this product specification sheet are supplied by way of information only and are not binding.

Socla reserves the right to carry out any technical and design improvements to its products without prior notice. Warranty : All sales and contracts for sale are expressly conditioned on the buyer's assent to Socla terms and conditions found on its website at www.socla.com. Socla hereby objects to any term, different from or additional to Socla terms, contained in any buyer communication in any form, unless agreed to in a writing signed by an officer of Socla.



A WATTS Brand

Socla sas

365 rue du Lieutenant Putier • 71530 Virey-Le-Grand • France

Tel. +33 03 85 97 42 00 • Fax +33 03 85 97 42 42

contact@wattswater.com • www.socla.com

ISO 9001 version 2015 / ISO 18001